



PNEUMATIC TIRE FORKLIFT

3,000-7,000 LB CAPACITY LP GAS, GASOLINE AND DIESEL MODELS
YOUR GO-TO PNEUMATIC TIRE FORKLIFT TRUCK



COMFORT COMES STANDARD.

STEP INTO THE OPERATOR COMPARTMENT OF AN FG15N-FG35N / FD20N-FD35N



Comfortable Operator Compartment:

With three-point access, operators of any size can easily enter the operator compartment of these Mitsubishi forklift trucks. The large floor space provides maximum operator comfort, especially during long shifts, while the “through the floor” pedal design further reduces operator fatigue and discomfort throughout the day.

Operator Comfort: Optional fingertip control armrest provides operators with low-effort levers and length / height adjustment, all while increasing precision and control.

Enhanced Operator Visibility:

From the standard lighting package, which includes two forward LED work lights, to the absence of crossbars in the overhead guard and the specially-designed mast, the design of the forklift allows for improved visibility in all directions during operation.

Adjustable Steering: The forklift’s steering column is equipped with standard memory tilt steering. Allowing for infinite adjustment in a 12 degree range, the steering column’s “memory” feature retains the operator’s preferred settings for added convenience and comfort during operation.

- Designed for operator comfort
- Adjustable seating for flexibility
- Enhanced visibility
- Memory tilt steering

All come together to create a working environment that reduces fatigue through even the longest shifts.

Every operator is different, so the key to creating a comfortable shift is a flexible design.





Features	Standard	Optional
Ergonomic seat	●	
Memory tilt steering column	●	
Integrated Presence System	●	
Two forward work lights	●	
Full-suspension seat		●
Swivel seat package		●
Swing-down LP tank bracket		●

The FG15N series delivers superior lift and travel speeds, powerful acceleration and the ability to move 7,800 more loads per year than the competition*. Gain up to 8% more productivity with Mitsubishi forklift trucks.

*Based on cycle testing in which this model completed three more cycles in an hour than the leading competitors. Assuming 10-hour shifts, five-day work weeks and a 52-week year, these results can be calculated to run up to 7,800 more cycles than the leading competition in a given year.

PERFORMANCE AND SERVICE.

QUALITY COMPONENTS AND EASY MAINTENANCE MEAN INCREASED UPTIME



- Smooth powerful engines
- Enhanced engine protection
- Reliable components
- Easy service access
- Flexible options

These forklifts are built to perform from the ground up.

LPG / Gas Engine - Efficient From The Inside Out

Equipped with an efficient GK21 / GK25 engine, these forklifts offer the power you need. A drive-by-wire throttle control allows for enhanced efficiency, reduced emissions and responsive acceleration, while the exhaust system provides a three-way catalyst that lowers the amount of emissions released into the environment.

Diesel Engine - Now Tier 4 Final Compliant

The new 4EG 3.3L diesel engine is built with cutting-edge emissions technologies to meet the Environmental Protection Agency's (EPA) Tier 4 final requirements, while still maintaining the high levels of productivity that your business demands. These include:

- **Utilizing a high pressure common rail fuel injection system** – to ensure the diesel burns cleanly with optimum power output.
- **Employing an exhaust gas recirculation system** – this sends exhaust gas back through the system after cooling to limit harmful emissions, while a diesel oxidation catalyst oxidizes harmful particulate matter.



Cool And Quiet: The forklift's fan and radiator system is equipped with a horizontal cross flow cooling system to help keep the engine cool and functioning at peak performance. The corrugated design provides optimal heat exchange, while the aluminum core helps to prevent corrosion. The direct drive fan also reduces noise and necessary maintenance, benefiting your operators and your business.

Engine Protection: Regulated by the Vehicle Control Module, the Engine Protection System keeps the truck running at desirable levels while helping to prevent damage to the forklift, saving you money. If any of the vital fluids become critically low, RPM levels are automatically lowered and the operator is immediately notified by a light on the dash display.

Easy Service Access: Tool-free access to the engine compartment makes routine maintenance, such as cleaning radiator fins, much easier. Additionally, the Vehicle Control Module is conveniently located under the dashboard cup holder, making it readily accessible.



Additional options are available to customize the forklift for your application:

- Bottler's Tilt
- Square Fin Radiator
- Warning Lights
- Air Intake Precleaner
- Underbelly Screen
- Fuel Saver Mode
- Foundry/Brick Protection
- Cotton Fiber Protection

CHARACTERISTICS			FG15N		FG18N		FG20CN		FG20N	
1	Capacity at rated load center	lb kg	3,000	1,500	3,500	1,750	4,000	2,000	4,000	2,000
2	Capacity at load center – distance	in mm	24	500	24	500	24	500	24	500
3	Power		gasoline/LPG		gasoline/LPG		gasoline/LPG		gasoline/LPG	
4	Tire type		pneumatic		pneumatic		pneumatic		pneumatic	
5	Wheels (x = driven)		2x / 2		2x / 2		2x / 2		2x / 2	
DIMENSIONS										
6	Maximum fork height – with standard two-stage mast	in mm	131	3,325	131	3,325	131	3,325	131.5	3,340
7	Free fork height – with standard two-stage mast	in mm	4.5	115	4.5	115	4.7	120	5.5	140
8	Fork dimensions – length x width x thickness	in mm	1.4 x 42.0 x 3.9	35 x 1,070 x 100	1.4 x 42.0 x 3.9	35 x 1,070 x 100	1.6 x 42.0 x 3.9	40 x 1,070 x 100	1.6 x 42.0 x 3.9	40 x 1,070 x 100
9	Fork spacing, out-to-out minimum / maximum	in mm	7.9 / 36.2	200 / 920	7.9 / 36.2	200 / 920	7.9 / 36.2	200 / 920	8.7 / 39.4	220 / 1,000
10	Tilt, forward / backward	deg	6° / 10°		6° / 10°		6° / 10°		6° / 10°	
11	Length to fork face	in mm	89.0	2,260	90.4	2,295	92.5	2,350	98.0	2,490
12	Overall width with standard tires	in mm	41.9	1,065	41.9	1,065	41.9	1,065	45.3	1,150
13	Overall width with optional duals	in mm	-		-		-		64.6	1,640
14	Height with lowered mast	in mm	84.5	2,140	84.5	2,140	84.5	2,140	84.5	2,145
15	Seat height	in mm	44.4	1,127	44.4	1,127	44.4	1,127	44.8	1,137
16	Height to top of overhead guard	in mm	82.7	2,100	82.7	2,100	82.7	2,100	82.9	2,105
17	Height with extended mast	in mm	179	4,549	179	4,549	179	4,549	180	4,564
18	Minimum outside turning radius	in mm	76.8	1,950	78.0	1,980	79.5	2,020	86.6	2,200
19	Load moment constant	in mm	15.7	400	15.7	400	16.3	415	17.9	455
20	Minimum aisle – 90° stack – zero clearance without load	in mm	92.5	2,350	93.7	2,380	95.9	2,435	105	2,655
PERFORMANCE										
21	Travel speed, loaded / empty	mph km/h	10.9 / 11.8	17.5 / 19.0	10.9 / 11.8	17.5 / 19.0	11.2 / 11.5	18.0 / 18.5	10.6 / 11.5	17.0 / 18.5
22	Lift speed, loaded / empty	fpm mm/s	122 / 124	0.62 / 0.63	122 / 124	0.62 / 0.63	122 / 124	0.62 / 0.63	112 / 116	0.57 / 0.59
23	Lowering speed, loaded / empty	fpm m/s	98.4 / 98.4	0.50 / 0.50	98.4 / 98.4	0.50 / 0.50	98.4 / 98.4	0.50 / 0.50	98.4 / 98.4	0.50 / 0.50
24	Drawbar pull loaded (60-minute rating)	lb N	3,910	17,400	3,910	17,400	3,870	17,200	3,840	17,100
25	Drawbar pull loaded maximum (5-minute rating)	lb N	4,560	20,300	4,560	20,300	4,500	20,000	4,500	20,000
26	Gradeability loaded at 1 mph (1.6 km)	%	39.0		39.0		38.0		35.0	
27	Gradeability maximum, loaded / empty	%	63.0		55.0		46.0		41.0	
WEIGHT										
28	Empty	lb kg	5,650	2,560	6,070	2,750	6,750	3,040	7,370	3,340
29	Axle load with rated load, front / rear (est.)	lb kg	7,710 / 940	3,620 / 440	8,460 / 1,110	3,980 / 520	9,370 / 1,380	4,390 / 650	9,950 / 1,420	4,660 / 685
30	Axle load without load, front / rear (est.)	lb kg	2,490 / 3,160	1,130 / 1,430	2,370 / 3,700	1,080 / 1,670	2,390 / 4,360	1,080 / 1,960	3,240 / 4,130	1,470 / 1,870
CHASSIS										
31	Tire size – front (standard)	in	6.5 x 10 - 10PR		6.5 x 10 - 10PR		6.5 x 10 / 5.0 Solid		7.0 x 12 - 12PR	
32	Tire size – front (optional duals)	in	-		-		-		7.0 x 12 - 12PR	
33	Tire size – rear	in	5.0 x 8 - 10PR		5.0 x 8 - 10PR		5.0 x 8 / 3.0 Solid		6.0 x 9 - 10PR	
34	Wheelbase	in mm	55.1	1,400	55.1	1,400	55.1	1,400	63.0	1,600
35	Tread width – front (standard tires)	in mm	35.0	890	35.0	890	35.0	890	37.8	960
36	Tread width – front (optional duals)	in mm	-		-		-		47.4	1,205
37	Tread width – rear	in mm	35.4	900	35.4	900	35.4	900	38.6	980
38	Ground clearance at lowest point of mast	in mm	4.3	110	4.3	110	4.3	110	4.6	117
39	Ground clearance at center of wheelbase	in mm	6.0	152	6.0	152	6.0	152	6.6	167
40	Service brakes	type	foot-operated, hydraulic		foot-operated, hydraulic		foot-operated, hydraulic		foot-operated, hydraulic	
41	Parking brakes	type	hand, mechanical		hand, mechanical		hand, mechanical		hand, mechanical	
ELECTRICAL										
42	Engine model		GK21E		GK21E		GK21E		GK21E	
43	Continuous output S.A.E. gross	HP kW	53.0	39.6	53.0	39.6	53.0	39.6	53.0	39.6
44		at rpm	2,700		2,700		2,700		2,700	
45	Maximum torque S.A.E. gross	lb-ft Nm	110	149	110	149	110	149	110	149
46		at rpm	2,000		2,000		2,000		2,000	
47	Cylinders / displacement	cu in L	4 / 126	4 / 2.1	4 / 126	4 / 2.1	4 / 126	4 / 2.1	4 / 126	4 / 2.1
48	Transmission type		powershift		powershift		powershift		powershift	
49	Number of speeds, forward / reverse		1 / 1		1 / 1		1 / 1		1 / 1	
50	Battery		12		12		12		12	
51	Relief pressure for attachments	psi bar	2,610	180	2,610	180	2,610	180	2,610	180
52	Noise level – mean value at operator's ear Leq	dB(A)	73.5		73.5		73.5		73.5	

SAFETY STANDARDS

These trucks meet American National Standards Institute/Industrial Truck Standards Development Foundation, ANSI/ITSDF B56.1. UL-Classified by Underwriters Laboratories, Inc., as to fire and electric shock hazard only. Availability: Types G, LP and D standard. Types GS, LPS and DS optional. Users should be aware of, and adhere to, applicable codes and regulations regarding operator training, use, operation and maintenance of powered industrial trucks, including:

- ANSI/ITSDF B56.1.
- NFPA 505, fire safety standard for powered industrial trucks - type designations, areas of use, maintenance and operation.
- Occupational Safety and Health Administration (OSHA) regulations that may apply.

Specifications, equipment, technical data, photos and illustrations based on information at time of printing and subject to change without notice. Some products may be shown with optional equipment.

	FD20N		FG25N		FD25N		FG28N		FD28N		FG30N	
1	4,000	2,000	5,000	2,500	5,000	2,500	5,500	2,800	5,500	2,800	6,000	3,000
2	24	500	24	500	24	500	24	500	24	500	24	500
3	diesel		gasoline/LPG		diesel		gasoline/LPG		diesel		gasoline/LPG	
4	pneumatic		pneumatic		pneumatic		pneumatic		pneumatic		pneumatic	
5	2x / 2		2x / 2		2x / 2		2x / 2		2x / 2		2x / 2	
6	131.5	3,340	131.5	3,340	131.5	3,340	130.5	3,315	130.5	3,315	130.5	3,315
7	5.5	140	5.5	140	5.5	140	5.7	145	5.7	145	5.7	145
8	1.6x42.0x3.9	40x1,070x100	1.6x42.0x3.9	40x1,070x100	1.6x42.0x3.9	40x1,070x100	1.8x42.0x4.9	45x1,070x125	1.8x42.0x4.9	45x1,070x125	1.8x42.0x4.9	45x1,070x125
9	8.7 / 39.4	220 / 1,000	8.7 / 39.4	220 / 1,000	8.7 / 39.4	220 / 1,000	9.8 / 39.4	250 / 1,000	9.8 / 39.4	250 / 1,000	9.8 / 39.4	250 / 1,000
10	6° / 10°		6° / 10°		6° / 10°		6° / 10°		6° / 10°		6° / 10°	
11	98.0	2,490	100	2,550	100.0	2,550	104	2,645	104	2,645	107	2,720
12	45.3	1,150	45.3	1,150	45.3	1,150	50.2	1,275	50.2	1,275	50.2	1,275
13	64.6	1,640	64.6	1,640	64.6	1,640	67.5	1,715	67.5	1,715	67.5	1,715
14	84.5	2,145	84.5	2,145	84.5	2,145	85.5	2,165	85.5	2,165	85.5	2,165
15	44.8	1,137	44.8	1,137	44.8	1,137	46.7	1,187	46.7	1,187	46.7	1,187
16	82.9	2,105	82.9	2,105	82.9	2,105	83.7	2,125	83.7	2,125	83.7	2,125
17	180	4,564	180	4,564	180	4,564	178.5	4,536	178.5	4,536	178.5	4,536
18	86.6	2,200	87.8	2,230	87.8	2,230	91.1	2,315	91.1	2,315	93.7	2,380
19	17.9	455	17.9	455	17.9	455	19.3	490	19.3	490	19.3	490
20	105	2,655	106	2,685	106	2,685	110	2,805	110	2,805	113	2,870
21	10.3 / 11.2	16.5 / 18.0	10.6 / 11.5	17.0 / 18.5	10.3 / 10.9	16.5 / 17.5	10.6 / 11.2	17.0 / 18.0	9.9 / 10.9	16.0 / 17.5	10.6 / 11.2	17.0 / 18.0
22	120 / 126	0.61 / 0.64	112 / 116	0.57 / 0.59	120 / 126	0.61 / 0.64	98.4 / 102	0.50 / 0.52	96.5 / 100	0.49 / 0.51	98.4 / 102	0.50 / 0.52
23	98.4 / 98.4	0.50 / 0.50	98.4 / 98.4	0.50 / 0.50	98.4 / 98.4	0.50 / 0.50	98.4 / 98.4	0.50 / 0.50	98.4 / 98.4	0.50 / 0.50	98.4 / 98.4	0.50 / 0.50
24	3,960	17,600	3,840	17,100	3,960	17,600	4,990	22,200	3,960	17,600	4,990	22,200
25	4,520	20,100	4,520	20,100	4,520	20,100	5,800	25,800	4,540	20,200	5,800	25,800
26	36.0		30.0		31.0		36.0		28.0		34.0	
27	42.0		36.0		37.0		43.0		32.0		41.0	
28	7,610	3,450	7,990	3,620	8,210	3,720	9,090	4,120	9,330	4,230	9,400	4,260
29	10,060 / 1,550	4,720 / 730	11,570 / 1,420	5,450 / 670	11,650 / 1,560	5,490 / 730	12,950 / 1,640	6,100 / 770	13,050 / 1,780	6,150 / 830	13,790 / 1,610	6,390 / 870
30	3,340 / 4,270	1,510 / 1,940	3,190 / 4,800	1,440 / 2,180	3,260 / 4,950	1,480 / 2,240	3,670 / 5,420	1,660 / 2,460	3,730 / 5,600	1,690 / 2,540	3,860 / 5,540	1,700 / 2,560
31	7.0 x 12 - 12PR		7.0 x 12 - 12PR		7.0 x 12 - 12PR		28 x 9 x 15 - 12PR		28 x 9 x 15 - 12PR		28 x 9 x 15 - 12PR	
32	7.0 x 12 - 12PR		7.0 x 12 - 12PR		7.0 x 12 - 12PR		28 x 9 x 15 - 12PR		28 x 9 x 15 - 12PR		28 x 9 x 15 - 12PR	
33	6.0 x 9 - 10PR		6.0 x 9 - 10PR		6.0 x 9 - 10PR		6.5 x 10 - 10PR		6.5 x 10 - 10PR		6.5 x 10 - 10PR	
34	63.0	1,600	63.0	1,600	63.0	1,600	63.8	1,620	63.8	1,620	66.9	1,700
35	37.8	960	37.8	960	37.8	960	41.7	1,060	41.7	1,060	41.7	1,060
36	47.4	1,205	47.4	1,205	47.4	1,205	47.2	1,200	47.2	1,200	47.2	1,200
37	38.6	980	38.6	980	38.6	980	38.6	980	38.6	980	38.6	980
38	4.6	117	4.6	117	4.6	117	5.4	136	5.4	136	5.4	136
39	6.6	167	6.6	167	6.6	167	7.4	189	7.4	189	7.4	189
40	foot-operated, hydraulic		foot-operated, hydraulic		foot-operated, hydraulic		foot-operated, hydraulic		foot-operated, hydraulic		foot-operated, hydraulic	
41	hand, mechanical		hand, mechanical		hand, mechanical		hand, mechanical		hand, mechanical		hand, mechanical	
42	4EG		GK21E		4EG		GK25E		4EG		GK25E	
43	48.0	36.0	53.0	39.6	48.0	36.0	61.0	45.8	48.0	36.0	61.0	45.8
44	2,250		2,700		2,250		2,700		2,250		2,700	
45	131	177	110	149	131	177	129	175	131	177	129	175
46	1,800		2,000		1,800		1,600		1,800		1,600	
47	4 / 203	4 / 3.3	4 / 126	4 / 2.1	4 / 203	4 / 3.3	4 / 152	4 / 2.5	4 / 203	4 / 3.3	4 / 152	4 / 2.5
48	powershift		powershift		powershift		powershift		powershift		powershift	
49	1 / 1		1 / 1		1 / 1		1 / 1		1 / 1		1 / 1	
50	12		12		12		12		12		12	
51	2,610	180	2,610	180	2,610	180	2,610	180	2,610	180	2,610	180
52	75.5		73.5		75.5		76.5		75.5		76.5	

CHARACTERISTICS			FD30N		FG33N		FD33N		FG35N	
1	Capacity at rated load center	lb kg	6,000	3,000	6,500	3,300	6,500	3,300	7,000	3,500
2	Capacity at load center – distance	in mm	24	500	24	500	24	500	24	500
3	Power		diesel		gasoline/LPG		diesel		gasoline/LPG	
4	Tire type		pneumatic		pneumatic		pneumatic		pneumatic	
5	Wheels (x = driven)		2x / 2		2x / 2		2x / 2		2x / 2	
DIMENSIONS										
6	Maximum fork height – with standard two-stage mast	in mm	130.5	3,315	131.5	3,350	131.5	3,350	131.5	3,350
7	Free fork height – with standard two-stage mast	in mm	5.7	145	5.9	150	5.9	150	5.9	150
8	Fork dimensions – length x width x thickness	in mm	1.8 x 42.0 x 4.9	45 x 1,070 x 125	2.0 x 42.0 x 4.9	50 x 1,070 x 125	2.0 x 42.0 x 4.9	50 x 1,070 x 125	2.0 x 42.0 x 4.9	50 x 1,070 x 125
9	Fork spacing, out-to-out minimum / maximum	in mm	9.8 / 39.4	250 / 1,000	9.8 / 39.4	250 / 1,000	9.8 / 39.4	250 / 1,000	9.8 / 39.4	250 / 1,000
10	Tilt, forward / backward	deg	6° / 10°		6° / 10°		6° / 10°		6° / 10°	
11	Length to fork face	in mm	107	2,720	108	2,750	108	2,750	110	2,790
12	Overall width with standard tires	in mm	50.2	1,275	50.2	1,275	50.2	1,275	50.8	1,290
13	Overall width with optional duals	in mm	67.5	1,715	67.5	1,715	67.5	1,715	67.5	1,715
14	Height with lowered mast	in mm	85.5	2,165	90.5	2,299	90.5	2,299	90.5	2,299
15	Seat height	in mm	46.7	1,187	46.7	1,187	46.7	1,187	46.7	1,187
16	Height to top of overhead guard	in mm	83.7	2,125	83.7	2,125	83.7	2,125	84.3	2,140
17	Height with extended mast	in mm	178.5	4,536	180	4,566	180	4,566	180	4,566
18	Minimum outside turning radius	in mm	93.7	2,380	95.7	2,430	95.7	2,430	96.1	2,440
19	Load moment constant	in mm	19.3	490	19.3	490	19.3	490	19.5	495
20	Minimum aisle – 90° stack – zero clearance without load	in mm	113	2,870	115	2,920	115	2,920	116	2,935
PERFORMANCE										
21	Travel speed, loaded / empty	mph km/h	9.9 / 10.9	16.0 / 17.5	10.9 / 11.5	17.5 / 18.5	10.3 / 11.2	16.5 / 18.0	10.9 / 11.5	17.5 / 18.5
22	Lift speed, loaded / empty	fpm mm/s	96.5 / 100	0.49 / 0.51	98.4 / 102	0.50 / 0.52	96.5 / 100	0.49 / 0.51	82.7 / 86.6	0.42 / 0.44
23	Lowering speed, loaded / empty	fpm m/s	98.4 / 98.4	0.50 / 0.50	98.4 / 98.4	0.50 / 0.50	98.4 / 98.4	0.50 / 0.50	98.4 / 98.4	0.50 / 0.50
24	Drawbar pull loaded (60-minute rating)	lb N	3,960	17,600	4,610	20,500	3,620	16,100	4,610	20,500
25	Drawbar pull loaded maximum (5-minute rating)	lb N	4,540	20,200	5,310	23,600	4,140	18,400	5,310	23,600
26	Gradeability loaded at 1 mph (1.6 km)	%	26.0		29.0		22.0		27.0	
27	Gradeability maximum, loaded / empty	%	30.0		33.0		25.0		32.0	
WEIGHT										
28	Empty	lb kg	9,640	4,370	10,150	4,600	10,390	4,710	10,340	4,690
29	Axle load with rated load, front / rear (est.)	lb kg	13,890 / 1,750	6,550 / 820	14,590 / 2,060	6,880 / 970	14,700 / 2,190	6,920 / 1,040	15,400 / 1,990	7,250 / 940
30	Axle load without load, front / rear (est.)	lb kg	3,920 / 5,720	1,770 / 2,600	3,790 / 6,360	1,710 / 2,890	3,890 / 6,500	1,760 / 2,950	3,700 / 6,640	1,680 / 3,010
CHASSIS										
31	Tire size – front (standard)	in	28 x 9 x 15 - 12PR		250 x 15 - 16PR		250 x 15 - 16PR		250 x 15 - 16PR	
32	Tire size – front (optional duals)	in	28 x 9 x 15 - 12PR		28 x 9 x 15 - 12PR		28 x 9 x 15 - 12PR		28 x 9 x 15 - 12PR	
33	Tire size – rear	in	6.5 x 10 - 10PR		6.5 x 10 - 12PR		6.5 x 10 - 12PR		6.5 x 10 - 12PR	
34	Wheelbase	in mm	66.9	1,700	66.9	1,700	66.9	1,700	66.9	1,700
35	Tread width – front (standard tires)	in mm	41.7	1,060	41.7	1,060	41.7	1,060	41.7	1,060
36	Tread width – front (optional duals)	in mm	47.2	1,200	47.2	1,200	47.2	1,200	47.2	1,200
37	Tread width – rear	in mm	38.6	980	38.6	980	38.6	980	38.6	980
38	Ground clearance at lowest point of mast	in mm	5.4	136	5.4	136	5.4	136	5.7	146
39	Ground clearance at center of wheelbase	in mm	7.4	189	7.4	189	7.4	189	8.0	202
40	Service brakes	type	foot-operated, hydraulic		foot-operated, hydraulic		foot-operated, hydraulic		foot-operated, hydraulic	
41	Parking brakes	type	hand, mechanical		hand, mechanical		hand, mechanical		hand, mechanical	
ELECTRICAL										
42	Engine model		4EG		GK25E		4EG		GK25E	
43	Continuous output S.A.E. gross	HP kW	48.0	36.0	61.0	45.8	48.0	36.0	61.0	45.8
44		at rpm	2,250		2,700		2,250		2,700	
45	Maximum torque S.A.E. gross	lb-ft Nm	131	177	129	175	131	177	129	175
46		at rpm	1,800		1,600		1,800		1,600	
47	Cylinders / displacement	cu in L	4 / 203	4 / 3.3	4 / 152	4 / 2.5	4 / 203	4 / 3.3	4 / 152	4 / 2.5
48	Transmission type		powershift		powershift		powershift		powershift	
49	Number of speeds, forward / reverse		1 / 1		1 / 1		1 / 1		1 / 1	
50	Battery		12		12		12		12	
51	Relief pressure for attachments	psi bar	2,610	180	2,610	180	2,610	180	2,610	180
52	Noise level – mean value at operator's ear Leq	dB(A)	75.5		76.5		75.5		76.5	

SAFETY STANDARDS

These trucks meet American National Standards Institute/Industrial Truck Standards Development Foundation, ANSI/ITSDF B56.1. UL-Classified by Underwriters Laboratories, Inc., as to fire and electric shock hazard only. Availability: Types G, LP and D standard. Types GS, LPS and DS Option (subject to availability). Users should be aware of, and adhere to, applicable codes and regulations regarding operator training, use, operation and maintenance of powered industrial trucks, including:

- ANSI/ITSDF B56.1.
- NFPA 505, fire safety standard for powered industrial trucks - type designations, areas of use, maintenance and operation.
- Occupational Safety and Health Administration (OSHA) regulations that may apply.

Specifications, equipment, technical data, photos and illustrations based on information at time of printing and subject to change without notice. Some products may be shown with optional equipment.

FD35N		
1	7,000	3,500
2	24	500
3	diesel	
4	pneumatic	
5	2x / 2	
6	131.5	3,350
7	5.9	150
8	2.0x42.0x4.9	50x 1,070x 125
9	9.8 / 39.4	250 / 1,000
10	6° / 10°	
11	110	2,790
12	50.8	1,290
13	67.5	1,715
14	90.5	2,299
15	46.7	1,187
16	84.3	2,140
17	180	4,566
18	96.1	2,440
19	19.5	495
20	116	2,935
21	10.3 / 11.2	16.5 / 18.0
22	80.7 / 84.6	0.41 / 0.43
23	98.4 / 98.4	0.50 / 0.50
24	3,620	16,100
25	4,140	18,400
26	21.0	
27	24.0	
28	10,590	4,800
29	15,500 / 2,130	7,300 / 1,000
30	3,820 / 6,770	1,730 / 3,070
31	250 x 15 - 16PR	
32	28 x 9 x 15 - 12PR	
33	6.5 x 10 - 12PR	
34	66.9	1,700
35	41.7	1,060
36	47.2	1,200
37	38.6	980
38	5.7	146
39	8.0	202
40	foot-operated, hydraulic	
41	hand, mechanical	
42	4EG	
43	48.0	36.0
44	2,250	
45	131	177
46	1,800	
47	4 / 203	4 / 3.3
48	powershift	
49	1 / 1	
50	12	
51	2,610	180
52	75.5	

Call-out numbers shown in the diagram below correspond to the first column of the specifications chart.

FG15N-FG35N FD20N-FD35N

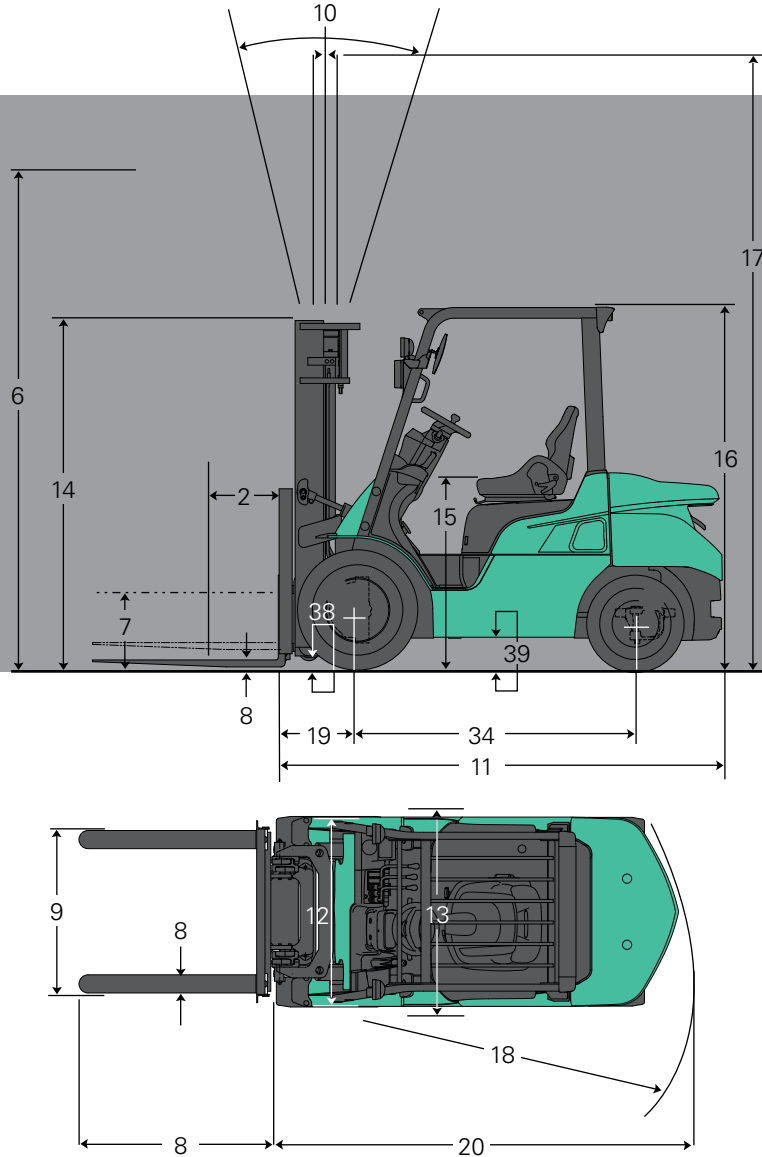

GOING THE EXTRA MILE.

HELPING KEEP OPERATORS AND PRODUCTS SECURE REQUIRES CONSTANT AWARENESS



Mitsubishi Forklift Trucks offers a selection of options designed specifically to help minimize risk and keep operators, pedestrians and your assets secure in the work environment.

Integrated Presence System:

The FG15N-FG35N / FD20-FD35N series is built to help protect the operator and surrounding personnel. Each forklift comes standard with the Integrated Presence System (IPS), which is designed to disengage all powered travel and some hydraulic functions when the operator leaves the normal operating position. A warning alarm will also sound and an indicator on the dash will appear if the operator leaves the compartment without applying the parking brake or forgets to fasten their seat belt.

Additional Options To Help Minimize Risk:

- **Rear grab bar with horn button** – This option allows the operator to easily access the horn while traveling in reverse, while the ergonomic placement of the rear grab bar creates a secure grip.
- **Ground speed control** – This programmable feature regulates top speeds and acceleration in environments where caution should be exercised.
- **Swing-down LP gas tank bracket** – Helping to reduce operator strain, this option makes it easier to remove and replace the empty fuel tank.
- **Light, strobe and alarm packages** – In dimly lit work areas, the optional rear work lights and strobe packages enhance operator visibility while increasing the visibility of the forklift to others working in the same area.
- **Fuel saver mode** – This system slows the acceleration of the forklift which allows savings of up to 14% in fuel efficiency without limiting the top speed of the truck.
- **Thermoformed overhead guard cover** – This plastic cover, offered in both clear or tinted, will help protect the operator from the elements while still allowing visibility through the overhead guard.

The Integrated Presence System provides audible and visual reminders to the operator.



Ground speed control allows you to set limits for the forklift's top speeds. This is especially useful in applications with pedestrian traffic.



FG15N-FG35N FD20N-FD35N

3,000-7,000 LB CAPACITY PNEUMATIC TIRE FORKLIFT

Delivering Exceptional Value

More Than 296,000 Parts To Keep You Running

Mitsubishi Forklift Trucks offers several parts programs, all designed to bring you top performance and convenience for your material handling needs. Contact your local dealer to put our services to work for you.

Support To Fit Your Operation

Find out why more companies are relying on Mitsubishi forklift truck dealers to keep their fleet operating at top performance. Our efficiency provides customers with a better return on investment, and qualified service technicians, diverse parts inventory and unparalleled selection of service options can help reduce your total cost of ownership.

Extensive Dealer Network

The Mitsubishi forklift truck dealer network is dedicated to finding the right forklift solution for your business. With more than 300 dealer locations, you can rely on your local dealer to provide the service you need when you need it most.



Manufactured with superior quality and exceptional value, Mitsubishi forklift trucks are supported by an extensive dealer and field support network located throughout North and South America. Don't forget to ask your local Mitsubishi forklift truck dealer about details on factory retail programs, financing plans and additional options and dealer services like planned maintenance and operator training.